

DCO1+ DCO1	X (mm)		Y (mm)	
	MIN	MAX	MIN	MAX
800	755	775	772	792
900	855	875	872	892
1000	955	975	972	992

# DB+DC01

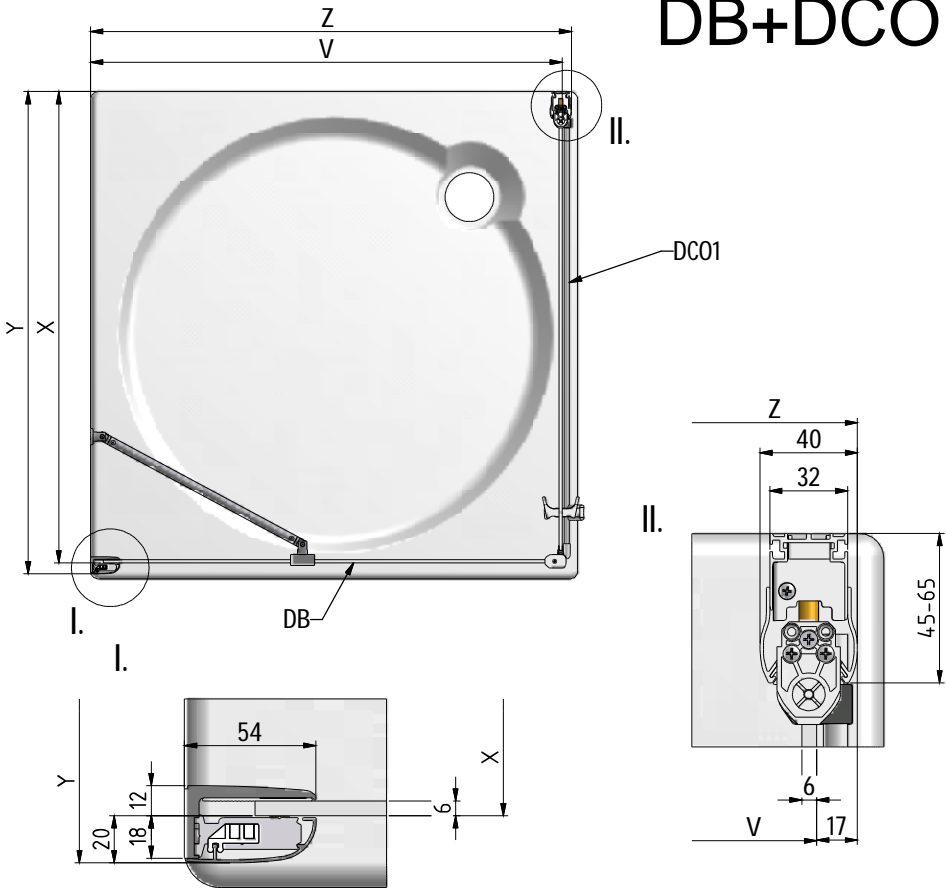

	DC01				DB			
	X(mm)		Y(mm)		V(mm)		Z(mm)	
	MIN	MAX	MIN	MAX	MIN	MAX	MIN	MAX
800	765	780	785	800	750	770	767	787
900	865	880	885	900	850	870	867	887
1000	965	980	985	1000	950	970	967	987